

FOUNDATION[®] Fieldbus Two-Wire pH/ORP Transmitter



For additional information, please refer to the Instruction Manuals CD shipped with this product, or visit our website at www.emersonprocess.com/rainhome/liquid/.

ESSENTIAL INSTRUCTIONS

READ THIS PAGE BEFORE PROCEEDING!

Your purchase from Rosemount Analytical, Inc. has resulted in one of the finest instruments available for your particular application. These instruments have been designed, and tested to meet many national and international standards. Experience indicates that its performance is directly related to the quality of the installation and knowledge of the user in operating and maintaining the instrument. To ensure their continued operation to the design specifications, personnel should read this manual thoroughly before proceeding with installation, commissioning, operation, and maintenance of this instrument. If this equipment is used in a manner not specified by the manufacturer, the protection provided by it against hazards may be impaired.

- Failure to follow the proper instructions may cause any one of the following situations to occur: Loss of life; personal injury; property damage; damage to this instrument; and warranty invalidation.
- Ensure that you have received the correct model and options from your purchase order. Verify that this manual covers your model and options. If not, call 1-800-854-8257 or 949-757-8500 to request correct manual.
- For clarification of instructions, contact your Rosemount representative.
- Follow all warnings, cautions, and instructions marked on and supplied with the product.
- Use only qualified personnel to install, operate, update, program and maintain the product.
- Educate your personnel in the proper installation, operation, and maintenance of the product.
- Install equipment as specified in the Installation section of this manual. Follow appropriate local and national codes. Only connect the product to electrical and pressure sources specified in this manual.
- Use only factory documented components for repair. Tampering or unauthorized substitution of parts and procedures can affect the performance and cause unsafe operation of your process.
- All equipment doors must be closed and protective covers must be in place unless qualified personnel are performing maintenance.
- If this equipment is used in a manner not specified by the manufacturer, the protection provided by it against hazards may be impaired.

WARNING

EXPLOSION HAZARD.

DO NOT OPEN WHILE CIRCUIT IS LIVE.

DO NOT RUB OR CLEAN WITH SOLVENTS.

9241589-00/A

SPECIFICATIONS - GENERAL

Case: ABS. panel mount, polycarbonate (pipe/surface mount). Both versions are NEMA 4X/CSA 4 (IP65).

Dimensions

Panel (code -10): 6.10 x 6.10 x 3.72 in. (155 x 155 x 94.5 mm)

Surface/Pipe (code -11): 6.23 x 6.23 x 3.23 in. (158 x 158 x 82 mm); see page 5 for dimensions of pipe mounting bracket.

Conduit openings: Accepts PG13.5 or 1/2 in. conduit fittings

Ambient Temperature: 32 to 122°F (0 to 50°C). Some degradation of display above 50°C.

Storage Temperature: -4 to 158°F (-20 to 70°C)

Relative Humidity: 10 to 90% (non-condensing)

Weight/Shipping Weight: 2 lb/3 lb (1 kg/1.5 kg)

Display: Two line, 16-character display. Character height: 4.8 mm; first line shows process variable (pH, ORP, conductivity, % concentration, oxygen, ozone, chlorine, or monochloramine), second line shows process temperature and output current. For pH/chlorine combination, pH may also be displayed. Fault and warning messages, when triggered, alternate with temperature and output readings.

During calibration and programming, messages, prompts, and editable values appear on the two-line display.

Temperature resolution: 0.1°C ($\leq 99.9^\circ\text{C}$); 1°C ($\geq 100^\circ\text{C}$)

Hazardous Location Approval: For details, see specifications for the measurement of interest.

RFI/EMI: EN-61326 

Digital Communications: For details, see specifications for the measurement of interest.

Power & Load Requirements: A power supply voltage of 9-32 Vdc at 13 mA is required.

FUNCTIONAL SPECIFICATIONS

pH Range: 0 to 14

ORP Range: -1400 to +1400mV

Calibrations/standardization: The automatic buffer recognition uses stored buffer values and their temperature curves for the most common buffer standards available worldwide. The transmitter also performs a stabilization check on the sensor in each buffer.

A manual two-point calibration is made by immersing the sensor in two different buffer solutions and entering the pH values. The microprocessor automatically calculates the slope which is used for self-diagnostics. An error message will be displayed if the pH sensor is faulty. This slope can be read on the display and/or manually adjusted if desired.

An on-line one-point process standardization is accomplished by entering the pH or ORP value of a grab sample.

Preamplifier Location: A preamplifier must be used to convert the high impedance pH electrode signal to a low impedance signal for transmitter use. The integral preamplifier of the Model Xmt-P may be used when the sensor to transmitter distance is less than 15 ft (4.5 m). Locate the preamplifier in the sensor or junction box for longer distances.

Automatic Temperature Compensation: External 3 or 4 wire Pt 100 RTD or Pt 1000 RTD located in the sensor, compensates the pH reading for temperature fluctuations. Compensation covers the range -15 to 130°C (5 to 270°F). Manual temperature compensation is also selectable.

Accuracy: $\pm 1 \text{ mV @ } 25^\circ\text{C} \pm 0.01 \text{ pH}$

Repeatability: $\pm 1 \text{ mV @ } 25^\circ\text{C} \pm 0.01 \text{ pH}$

Stability: 0.25% / year @ 25°C

Diagnostics: The internal diagnostics can detect:

Calibration Error	Sensor Failure
High Temperature Warning	CPU Failure
Low Temperature Warning	Input Warning
ROM Failure	Glass Warning
Glass Failure	Reference Warning
Reference Failure	

Once one of the above is diagnosed, the display will show a message describing the problem.

Digital Communications:

Fieldbus (pH): Four AI blocks assigned to pH, temperature, reference impedance, and glass impedance.

Fieldbus (ORP): Three AI blocks assigned to ORP, temperature, and reference impedance.

Fieldbus (pH and ORP): Execution time 75 msec. One PID block; execution time 150 msec. Device type 4085. Device revision 1. Certified to ITK 4.5.

SENSOR COMPATIBILITY CHART

pH/ORP SENSOR	DIAGNOSTIC CAPABILITY
320HP-58	Glass only
328A	Glass only
370	Glass only
371	Glass only
372	Glass only
381 pHE-31-41-52	Glass only
381+	Glass and Reference
385+	Glass and Reference
389-02-54 / 389VP-54	Glass only
396-54-62 / 396VP	Glass only
396P-55 / 396PVP-55	Glass and Reference
396R / 396RVP-54	Glass and Reference
397-54-62	Glass only
398-54-62 / 398VP-54	Glass only
398R-54-62 / 398RVP-54	Glass only
399-09-62 / 399VP-09 / 399-14	Glass only
Hx338	Glass only
Hx348	Glass only
TF396	none

QUICK START GUIDE

FOR MODEL SOLU COMP Xmt-P-FF/FI TRANSMITTER

1. Refer to page 5 for installation instructions.
2. Wire pH or ORP sensor to the transmitter. See Figure 6 for panel mount; Figure 7 for pipe or surface mount. Refer to the sensor instruction sheet for details.
3. Once connections are secure and verified, apply power to the transmitter.
4. When the transmitter is powered up for the first time, **Quick Start** screens appear. Using **Quick Start** is easy.
 - a. A blinking field shows the position of the cursor.
 - b. Use the \leftarrow or \rightarrow key to move the cursor left or right. Use the \uparrow or \downarrow key to move the cursor up or down or to increase or decrease the value of a digit. Use the \uparrow or \downarrow key to move the decimal point.
 - c. Press ENTER to store a setting. Press EXIT to leave without storing changes. Pressing EXIT also returns the display to the previous screen.

Measure?	pH
Redox	ORP

5. Choose measurement: **pH**, **ORP**, or **Redox**.

Use Preamplifier in?	
Xmtr	Sensor/JBox

6. Choose preamplifier location. Select **Xmtr** to use the integral preamplifier in the transmitter; select **Sensor/JBox** if your sensor has an integral preamplifier or if you are using a remote preamplifier located in a junction box.

Temperature in?	
C	F

7. Choose temperature units: **°C** or **°F**.

8. To change output settings, to scale the 4-20 mA output, to change measurement-related settings from the default values, and to set security codes, press MENU. Select Program and follow the prompts. Refer to the appropriate menu tree (page 11).

9. To return the transmitter to default settings, choose **ResetAnalyzer** in the Program menu.

UNPACKING AND INSPECTION

Inspect the shipping container. If it is damaged, contact the shipper immediately for instructions. Save the box. If there is no apparent damage, unpack the container. Be sure all items shown on the packing list are present. If items are missing, notify Emerson Process Management immediately.

INSTALLATION

1. Although the transmitter is suitable for outdoor use, do not install it in direct sunlight or in areas of extreme temperatures.
2. Install the transmitter in an area where vibrations and electromagnetic and radio frequency interference are minimized or absent.
3. Keep the transmitter and sensor wiring at least one foot from high voltage conductors. Be sure there is easy access to the transmitter.
4. The transmitter is suitable for panel (Figure 3), pipe (Figure 4), or surface (Figure 5) mounting.
5. The transmitter case has two 1/2-inch (PG13.5) conduit openings and either one or four 1/2-inch knockouts. The panel mount Xmt-P-FF/FI has four knockouts. The pipe/surface mount transmitter has two knockouts*. One conduit opening is for the power/output cable; the other opening is for the sensor cable.

Figure 1 shows how to remove a knockout. The knockout grooves are on the outside of the case. Place the screwdriver blade on the inside of the case and align it approximately along the groove. Rap the screwdriver sharply with a hammer until the groove cracks. Move the screwdriver to an uncracked portion of the groove and continue the process until the knockout falls out. Use a small knife to remove the flash from the inside of the hole.

6. Use weathertight cable glands to keep moisture out to the transmitter. If conduit is used, plug and seal the connections at the transmitter housing to prevent moisture from getting inside the instrument.
7. To reduce the likelihood of stress on wiring connections, do not remove the hinged front panel (-11 models) from the base during wiring installation. Allow sufficient wire leads to avoid stress on conductors.

**NEMA plug may be supplied instead of knockout for pipe/surface version.*

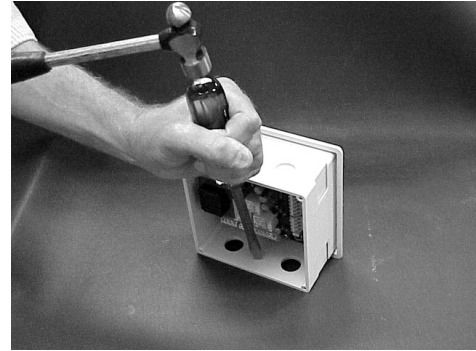

FIGURE 1. Removing the Knockouts

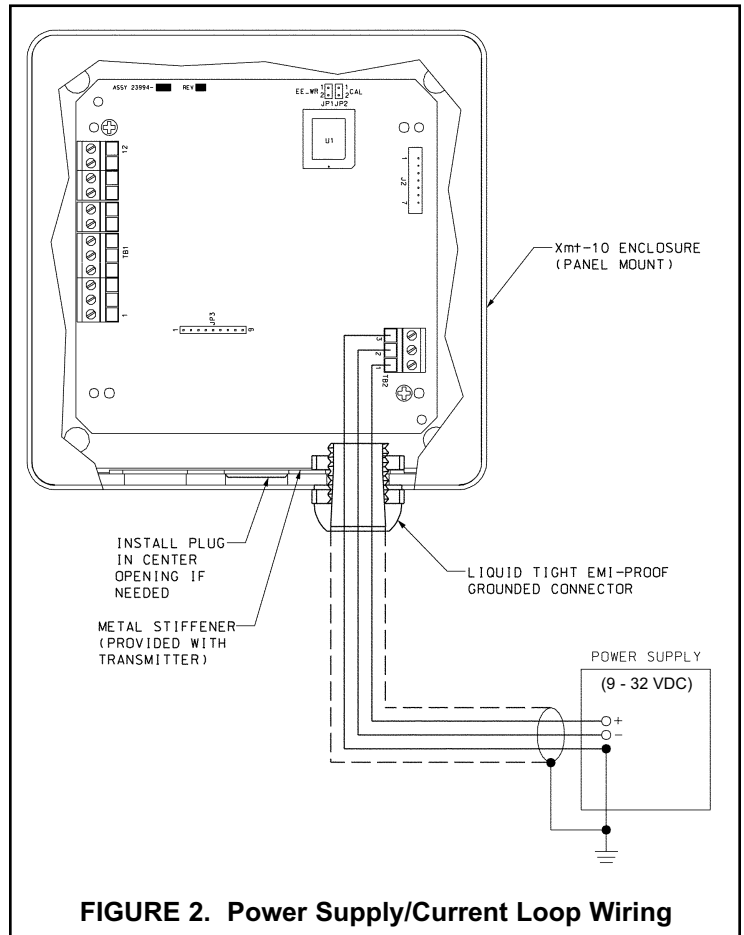
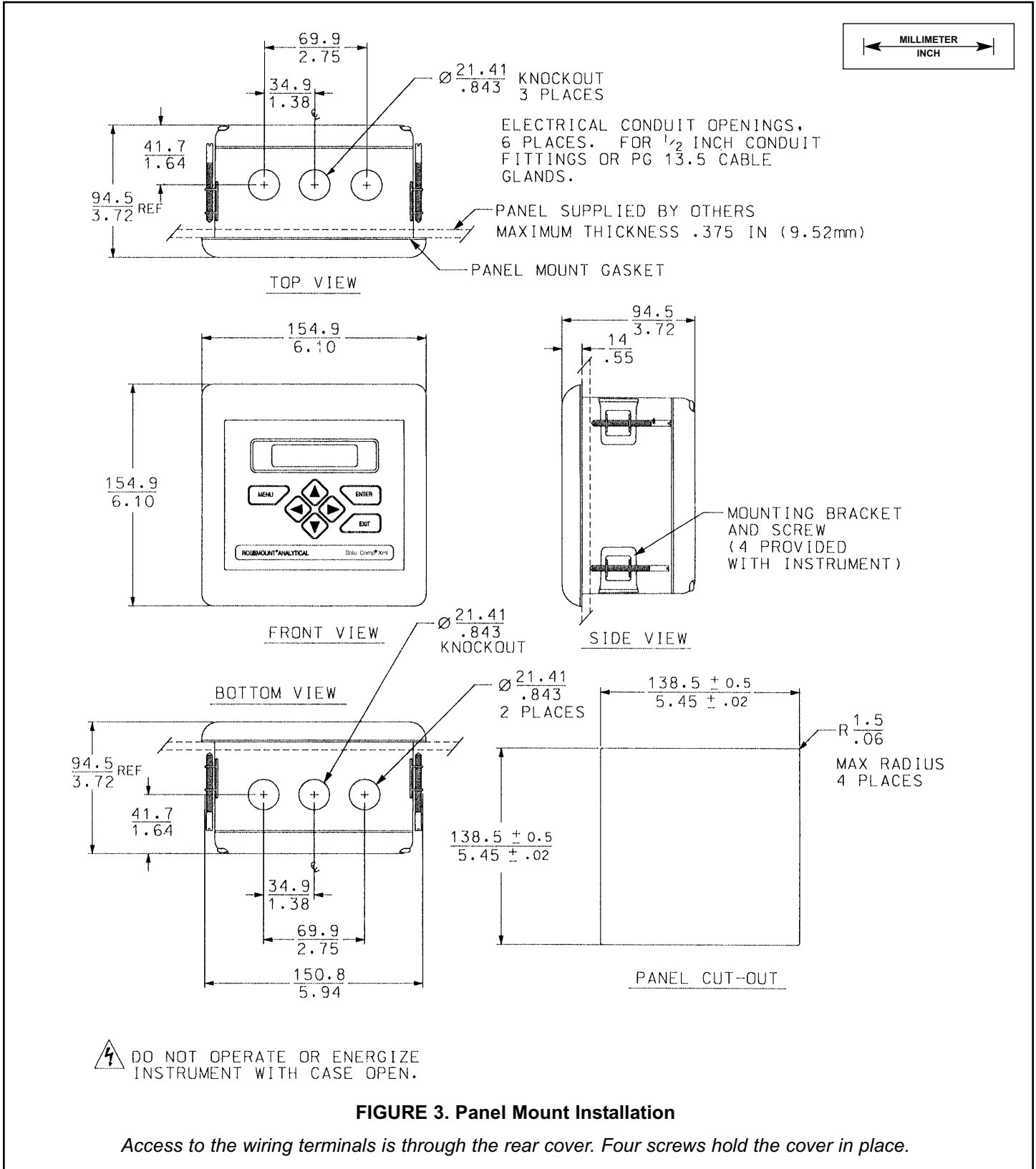
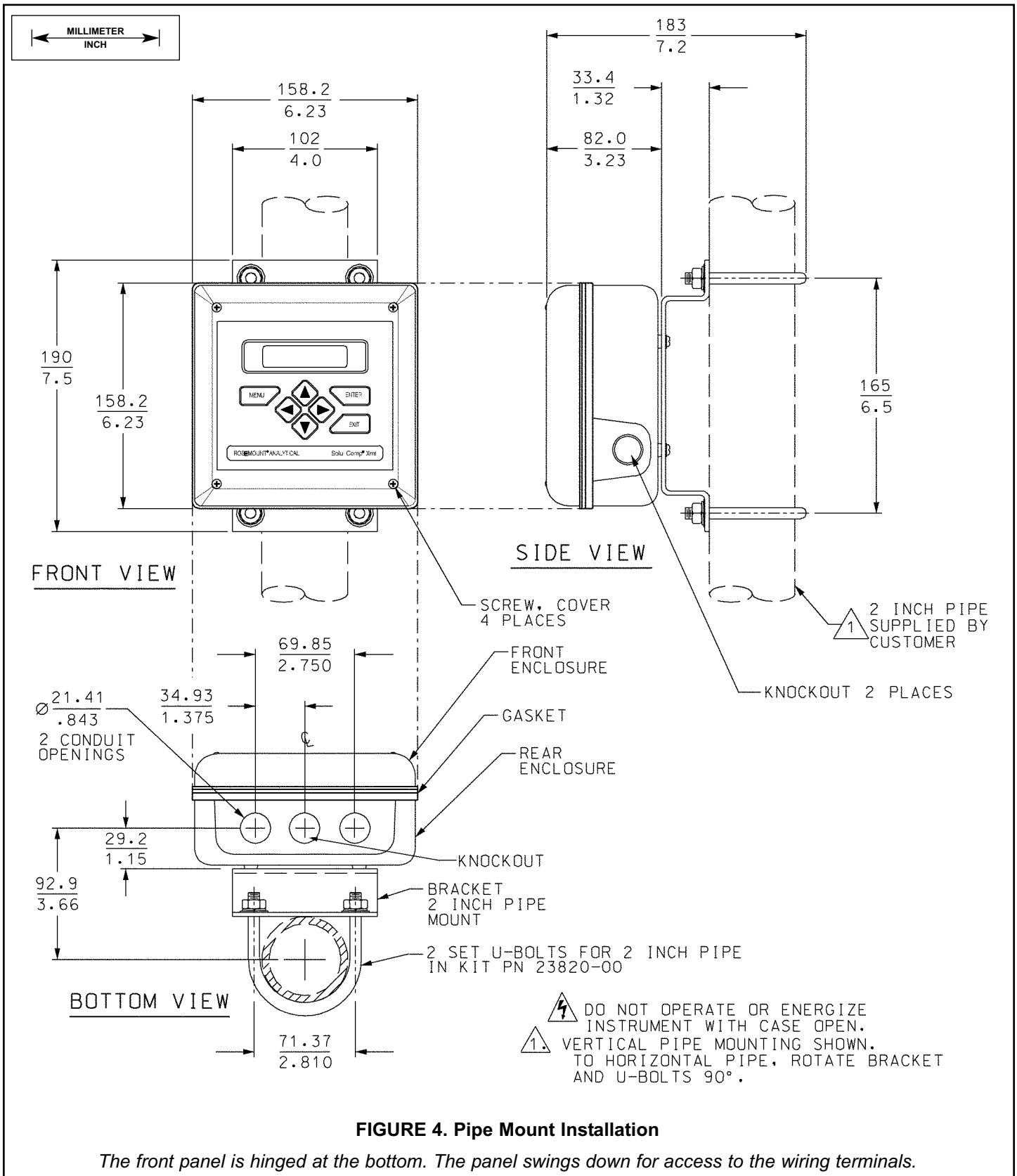

FIGURE 2. Power Supply/Current Loop Wiring

Panel Mounting.



Pipe Mounting.



Surface Mounting.

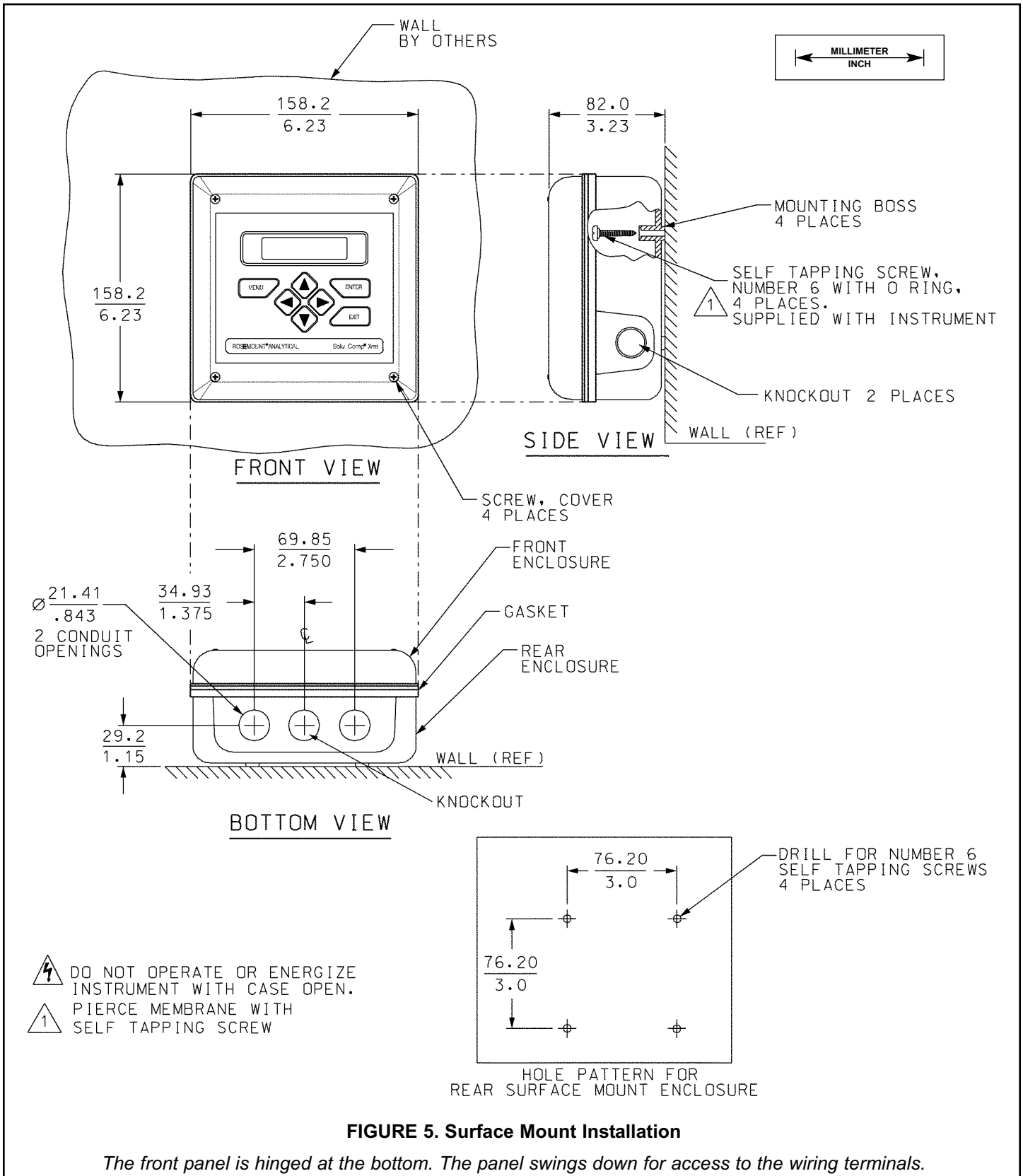

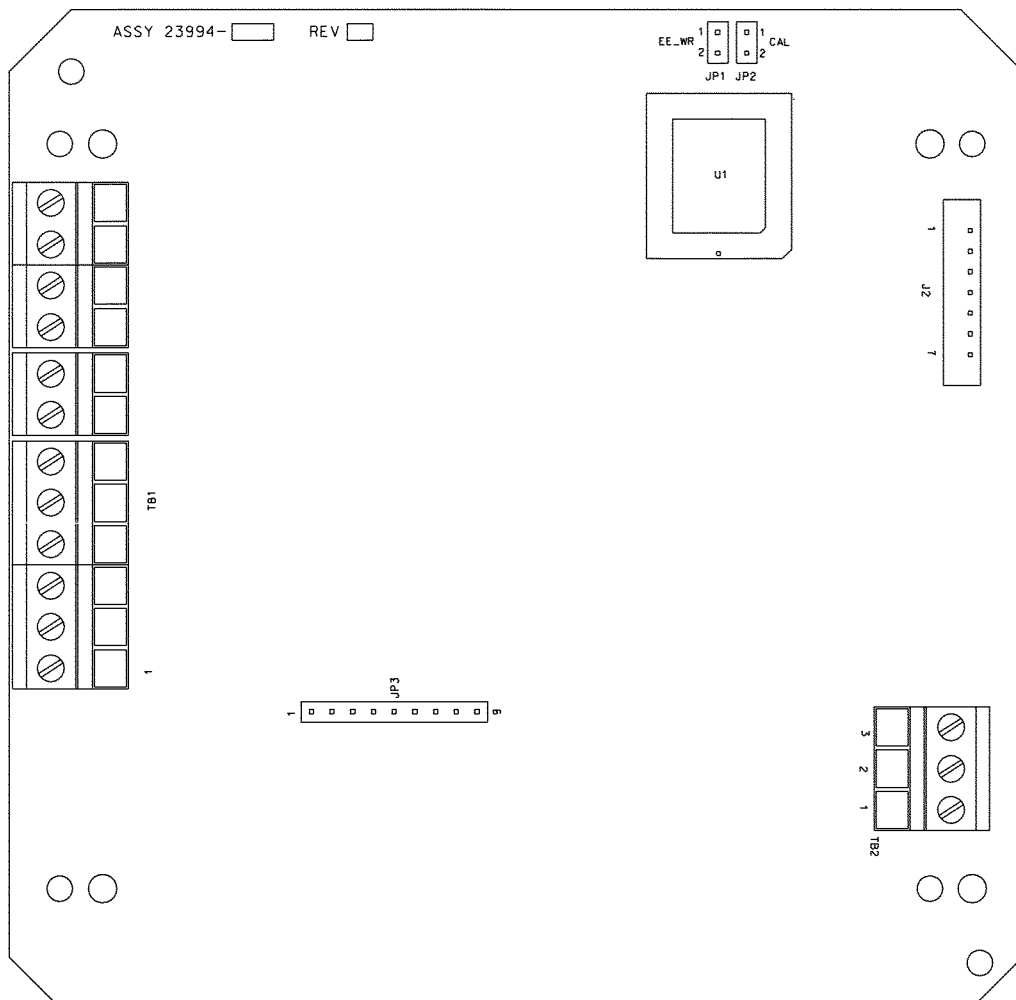

TB1		<p>pH/ORP CHLORINE/OXYGEN/OZONE</p>
12	CATHODE (NOT USED FOR pH/ORP)	
11	ANODE (NOT USED FOR pH/ORP)	
10	+ 5V	
9	- 5V	
8	pH/ORP IN	
7	pH/ORP GUARD	
6	SOLUTION GROUND	
5	REFERENCE IN	
4	REFERENCE GUARD	
3	RTD IN	
1	RTD RETURN	

TB2	
GROUND	3
4-20mA/FF -	2
4-20mA/FF +	1

9241587-00/A

FIGURE 6. Loop Power and Sensor Wiring - Panel Mount

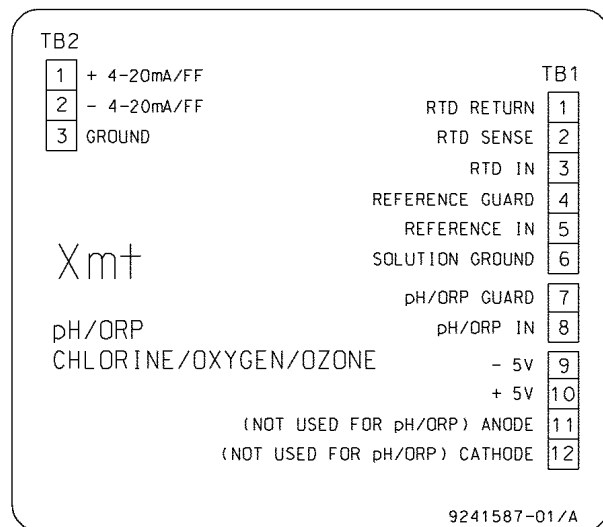
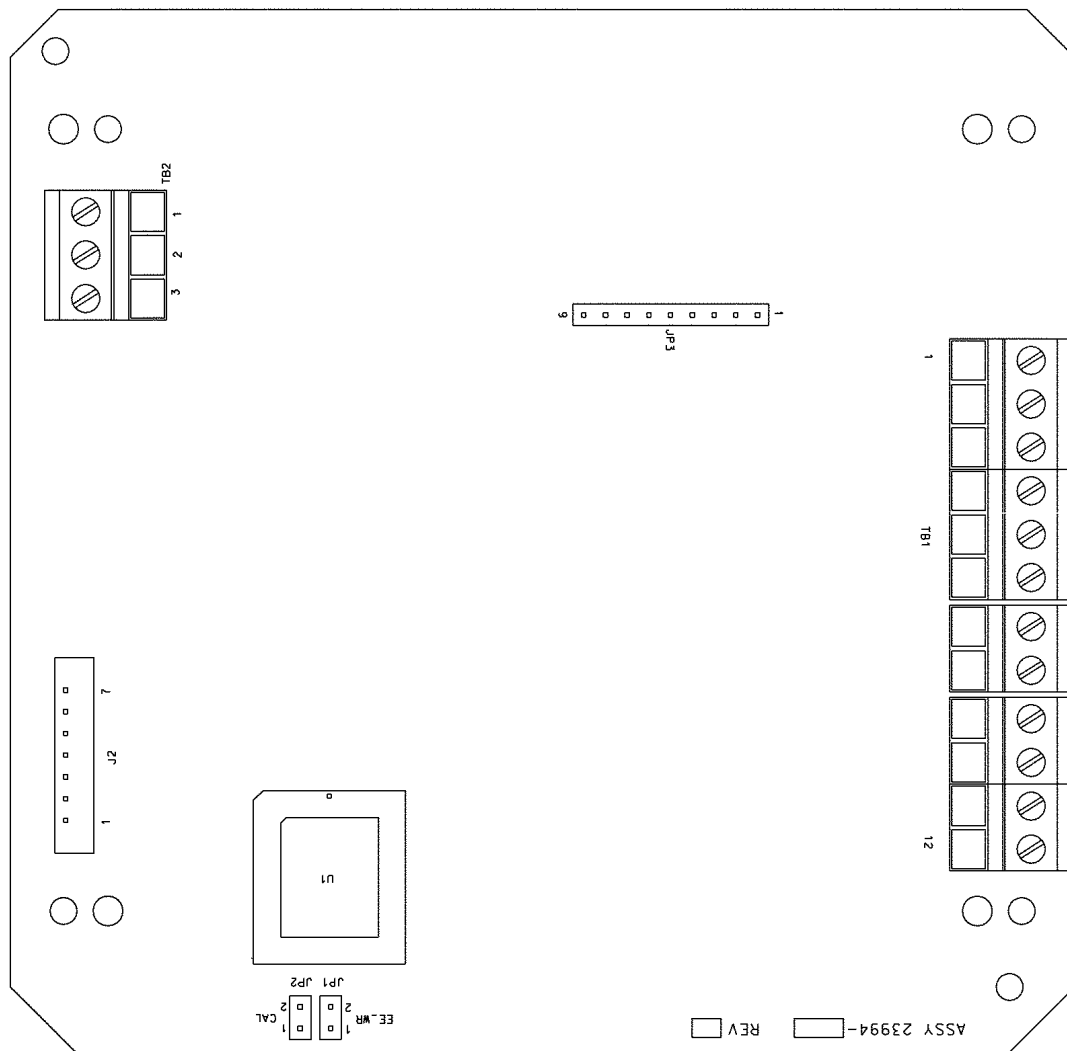
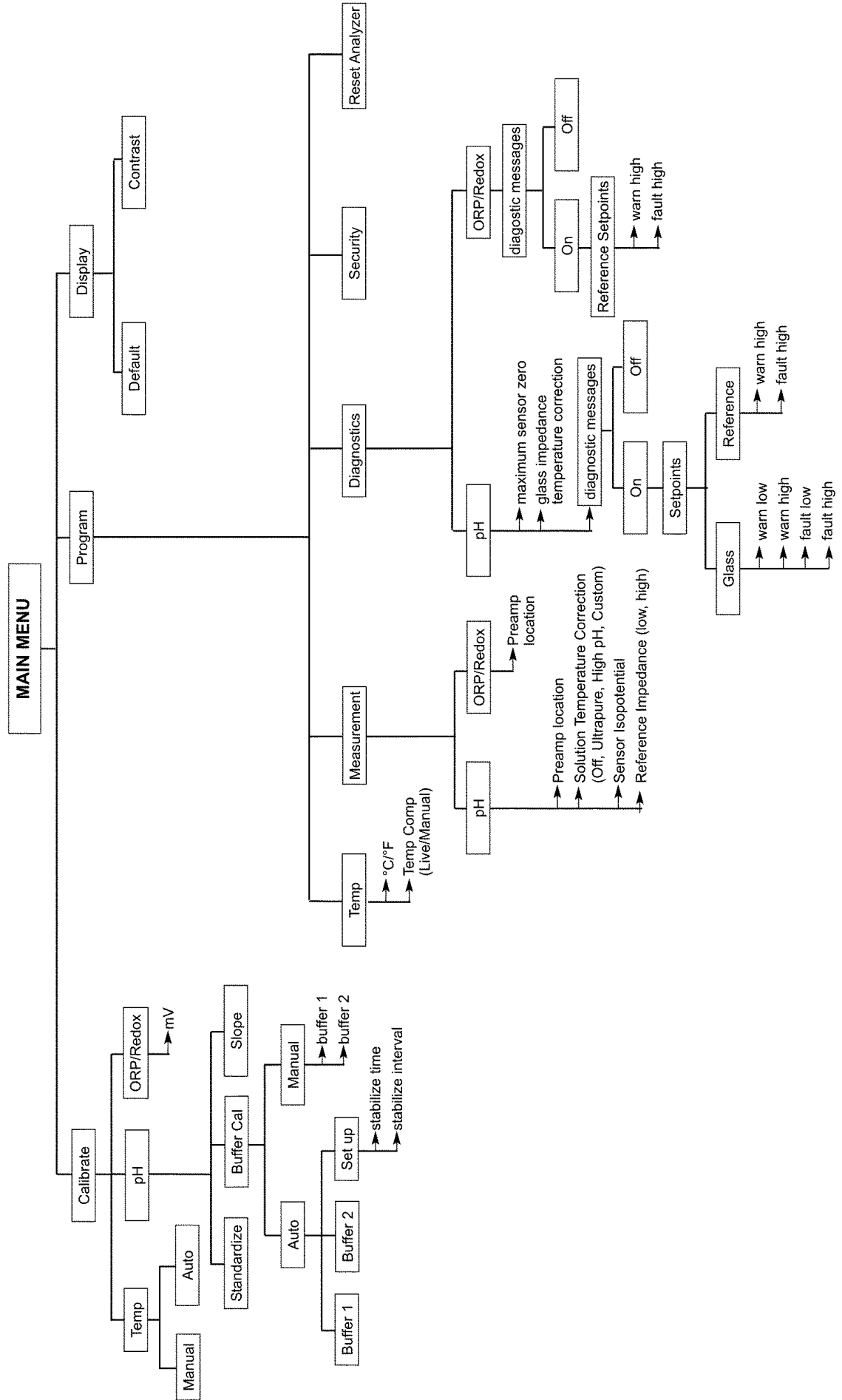
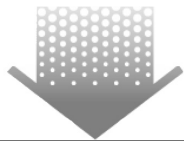

FIGURE 7. Loop Power and Sensor Wiring - Pipe/Surface Mount

MAIN MENU

MENU TREE FOR MODEL SOLU COMP Xmt-P-FF/FI TRANSMITTER





*The right people,
the right answers,
right now.*

ROSEMOUNT ANALYTICAL
CUSTOMER SUPPORT CENTER
1-800-854-8257



Emerson Process Management

Liquid Division

2400 Barranca Parkway
Irvine, CA 92606 USA
Tel: (949) 757-8500
Fax: (949) 474-7250

<http://www.raihome.com>

ON-LINE ORDERING NOW AVAILABLE ON OUR WEB SITE
<http://www.raihome.com>

Specifications subject to change without notice.



Credit Cards for U.S. Purchases Only.

